

## High Speed Infrared Emitting Diode in Side View Package

### Description

TSSF4500 is a high speed infrared emitting diode in GaAlAs on GaAlAs double hetero (DH) technology, molded in a clear, untinted plastic package with spherical side view lens.

The new technology combines the high speed of DH-GaAlAs with the efficiency of standard GaAlAs and the low forward voltage of the standard GaAs technology.

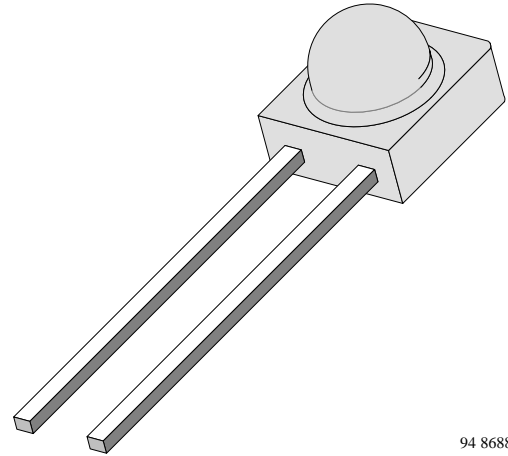

94 8688

### Features

- High modulation bandwidth (10 MHz)
- Extra high radiant power and high radiant intensity
- Low forward voltage
- Suitable for high pulse current operation
- Angle of half intensity  $\phi = \pm 22^\circ$
- Peak wavelength  $\lambda_p = 870 \text{ nm}$
- High reliability
- Good spectral matching to Si photodetectors

### Applications

Infrared high speed remote control and free air data transmission systems with high modulation frequencies or high data transmission rate requirements.

TSSF4500 is ideal for the design of transmission systems according to IrDA requirements and for carrier frequency based systems (e.g. ASK / FSK – coded, 450 kHz or 1.3 MHz).

### Absolute Maximum Ratings

$T_{\text{amb}} = 25^\circ\text{C}$

Parameter	Test Conditions	Symbol	Value	Unit
Reverse Voltage		$V_R$	5	V
Forward Current		$I_F$	100	mA
Peak Forward Current	$t_p/T=0.5, t_p=100 \mu\text{s}$	$I_{FM}$	200	mA
Surge Forward Current	$t_p=100 \mu\text{s}$	$I_{FSM}$	1.5	A
Power Dissipation		$P_V$	170	mW
Junction Temperature		$T_j$	100	$^\circ\text{C}$
Operating Temperature Range		$T_{\text{amb}}$	-40...+100	$^\circ\text{C}$
Storage Temperature Range		$T_{\text{stg}}$	-40...+100	$^\circ\text{C}$
Soldering Temperature	$t \leq 5\text{sec}, 2 \text{ mm from case}$	$T_{\text{sd}}$	260	$^\circ\text{C}$
Thermal Resistance Junction/Ambient		$R_{\text{thJA}}$	450	K/W

## Basic Characteristics

$T_{amb} = 25^{\circ}\text{C}$

Parameter	Test Conditions	Symbol	Min	Typ	Max	Unit
Forward Voltage	$I_F = 100 \text{ mA}, t_p = 20 \text{ ms}$	$V_F$		1.35	1.6	V
	$I_F = 1.5 \text{ A}, t_p = 100 \mu\text{s}$	$V_F$		2.4		V
Temp. Coefficient of $V_F$	$I_F = 100 \text{ mA}$	$TK_{V_F}$		-1.7		mV/K
Reverse Current	$V_R = 5 \text{ V}$	$I_R$			10	$\mu\text{A}$
Junction Capacitance	$V_R = 0 \text{ V}, f = 1 \text{ MHz}, E = 0$	$C_j$		160		pF
Radiant Intensity	$I_F = 100 \text{ mA}, t_p = 20 \text{ ms}$	$I_e$	10	20		mW/sr
	$I_F = 1 \text{ A}, t_p = 100 \mu\text{s}$	$I_e$		200		mW/sr
Radiant Power	$I_F = 100 \text{ mA}, t_p = 20 \text{ ms}$	$\phi_e$		25		mW
Temp. Coefficient of $\phi_e$	$I_F = 100 \text{ mA}$	$TK_{\phi_e}$		-0.7		%/K
Angle of Half Intensity		$\varphi$		$\pm 22$		deg
Peak Wavelength	$I_F = 100 \text{ mA}$	$\lambda_p$		870		nm
Spectral Bandwidth	$I_F = 100 \text{ mA}$	$\Delta\lambda$		40		nm
Temp. Coefficient of $\lambda_p$	$I_F = 100 \text{ mA}$	$TK_{\lambda_p}$		0.2		nm/K
Rise Time	$I_F = 100 \text{ mA}$	$t_r$		30		ns
Fall Time	$I_F = 100 \text{ mA}$	$t_f$		30		ns

## Dimensions in mm

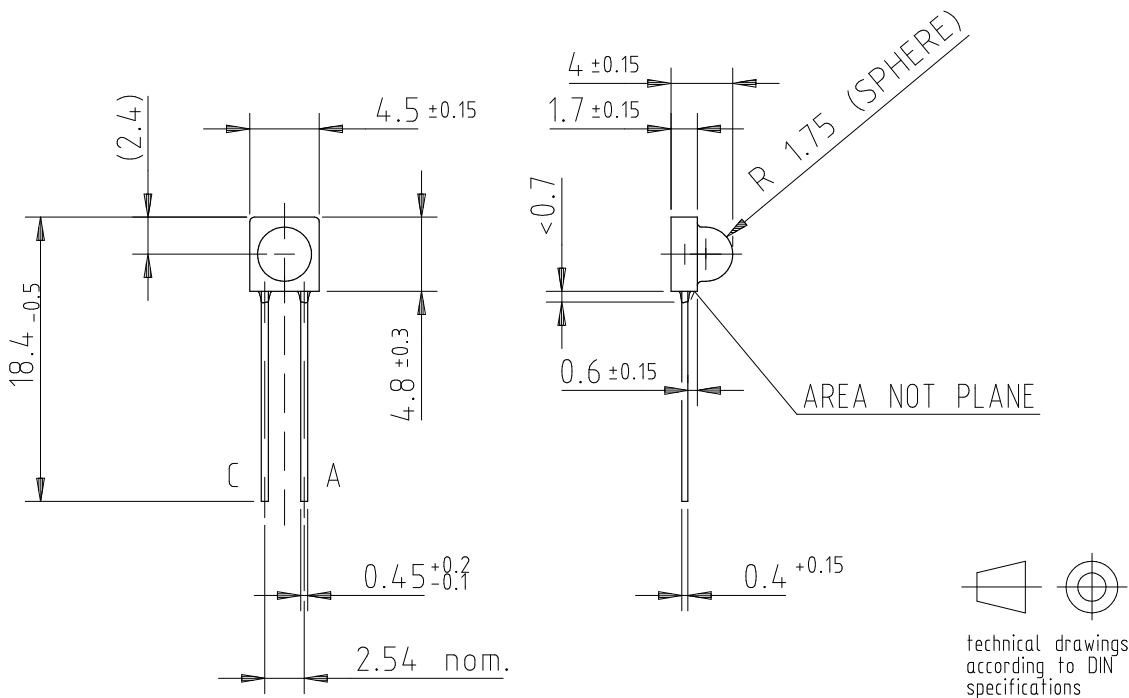

9612206

## **Ozone Depleting Substances Policy Statement**

It is the policy of **TEMIC TELEFUNKEN microelectronic GmbH** to

1. Meet all present and future national and international statutory requirements.
2. Regularly and continuously improve the performance of our products, processes, distribution and operating systems with respect to their impact on the health and safety of our employees and the public, as well as their impact on the environment.

It is particular concern to control or eliminate releases of those substances into the atmosphere which are known as ozone depleting substances (ODSs).

The Montreal Protocol (1987) and its London Amendments (1990) intend to severely restrict the use of ODSs and forbid their use within the next ten years. Various national and international initiatives are pressing for an earlier ban on these substances.

**TEMIC TELEFUNKEN microelectronic GmbH** semiconductor division has been able to use its policy of continuous improvements to eliminate the use of ODSs listed in the following documents.

1. Annex A, B and list of transitional substances of the Montreal Protocol and the London Amendments respectively
2. Class I and II ozone depleting substances in the Clean Air Act Amendments of 1990 by the Environmental Protection Agency (EPA) in the USA
3. Council Decision 88/540/EEC and 91/690/EEC Annex A, B and C (transitional substances) respectively.

**TEMIC** can certify that our semiconductors are not manufactured with ozone depleting substances and do not contain such substances.

**We reserve the right to make changes to improve technical design and may do so without further notice.**

Parameters can vary in different applications. All operating parameters must be validated for each customer application by the customer. Should the buyer use TEMIC products for any unintended or unauthorized application, the buyer shall indemnify TEMIC against all claims, costs, damages, and expenses, arising out of, directly or indirectly, any claim of personal damage, injury or death associated with such unintended or unauthorized use.

TEMIC TELEFUNKEN microelectronic GmbH, P.O.B. 3535, D-74025 Heilbronn, Germany  
Telephone: 49 (0)7131 67 2831, Fax number: 49 (0)7131 67 2423